

4000

Introduction • Topworks • Drives



Anchoring Solutions

Windlasses

Capstans

Accessories



AC DRIVE

DC DRIVE

HYDRAULIC DRIVE



Disclaimer

All information is subject to change without notice. For any critical requirement, use only specifically quoted figures, available on request.

MAXWELL

4000

Introduction • **Topworks** • Drives



Anchoring Solutions

Windlasses

Capstans

Accessories

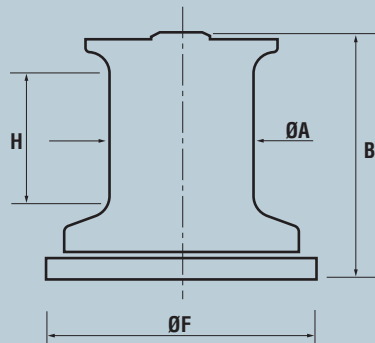

A	145mm 5 3/4"
B	260mm 10 1/4"
F	215mm 8 1/2"
H	160mm 6 5/16"

MAXWELL

4000

Introduction • Topworks • **Drives**



AC Drive Specifications

Anchoring Solutions

Windlasses

Capstans

Accessories

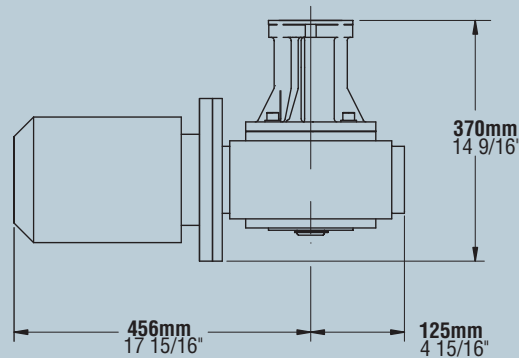

Line Speed	13 m/min 44 ft/min
Pull Capacity cont. run ①	715 kg 1576 lb
Pull Capacity stall	1818 kg 4000 lb
Current (At 400V)	
Rated Load	6.2 A
start DOL	41 A
Motor Power	3 kW 4 HP
Weight	76 kg 167 lb

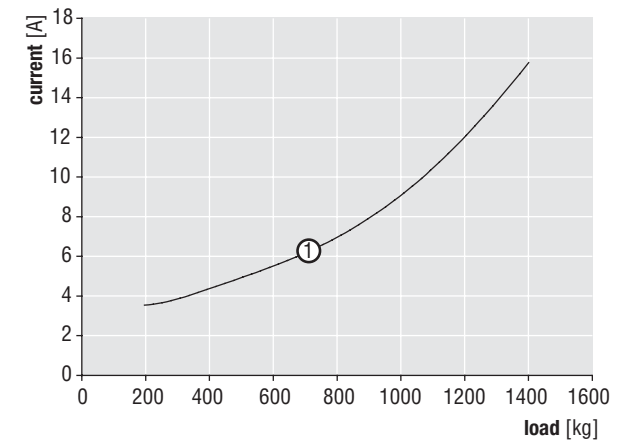

NOTE: Performance data are given for 400V 50Hz power supply.
They may vary for other voltages and frequencies.

MAXWELL

4000

Introduction • Topworks • **Drives**



DC Drive Specifications

Anchoring Solutions

Windlasses

Capstans

Accessories

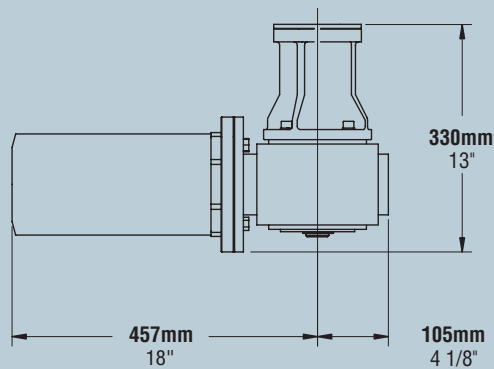

Pull Capacity	533 kg
cont. run (1)	1175 lb
Pull Capacity	1818 kg
stall	4000 lb
Motor Power	2 kW
	2.7 HP
Weight	53 kg
	117 lb

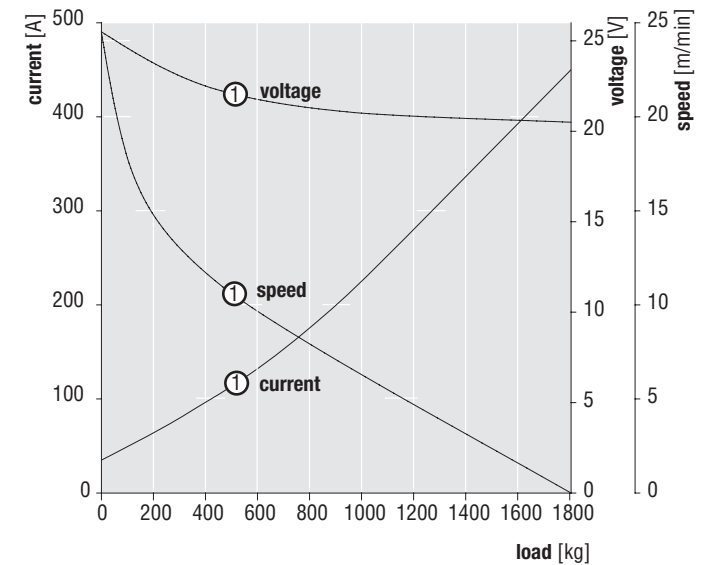

MAXWELL

4000

Introduction • Topworks • **Drives**



Anchoring Solutions

Windlasses

Capstans

Accessories

Hydraulic Drive Specifications

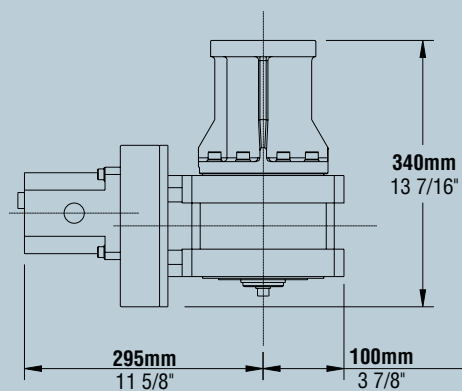

Maximum Pressure - p	103.4 bar 1500 psi
Pull Capacity	1818 kg 4000 lb
Recommended Flow - Q	50 l/min 13.2 USgal/min
Line Speed @ Q	14 m/min 46 ft/min
Maximum Flow	67 l/min 17.7 USgal/min
Weight	47 kg 104 lb

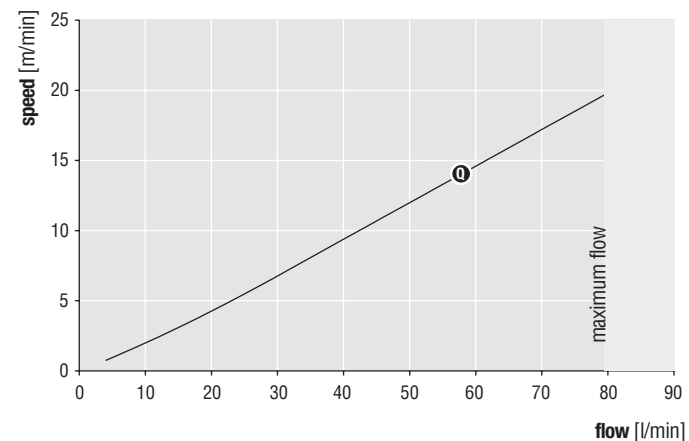
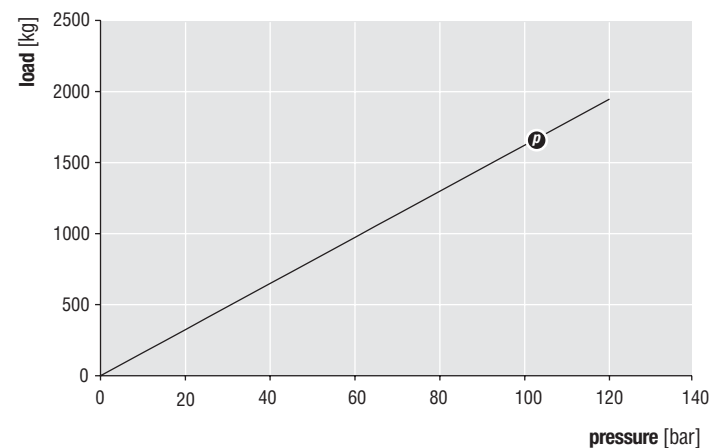

MAXWELL