

3500

Introduction • Topworks • Drives



Anchoring Solutions

Windlasses

Capstans

Accessories

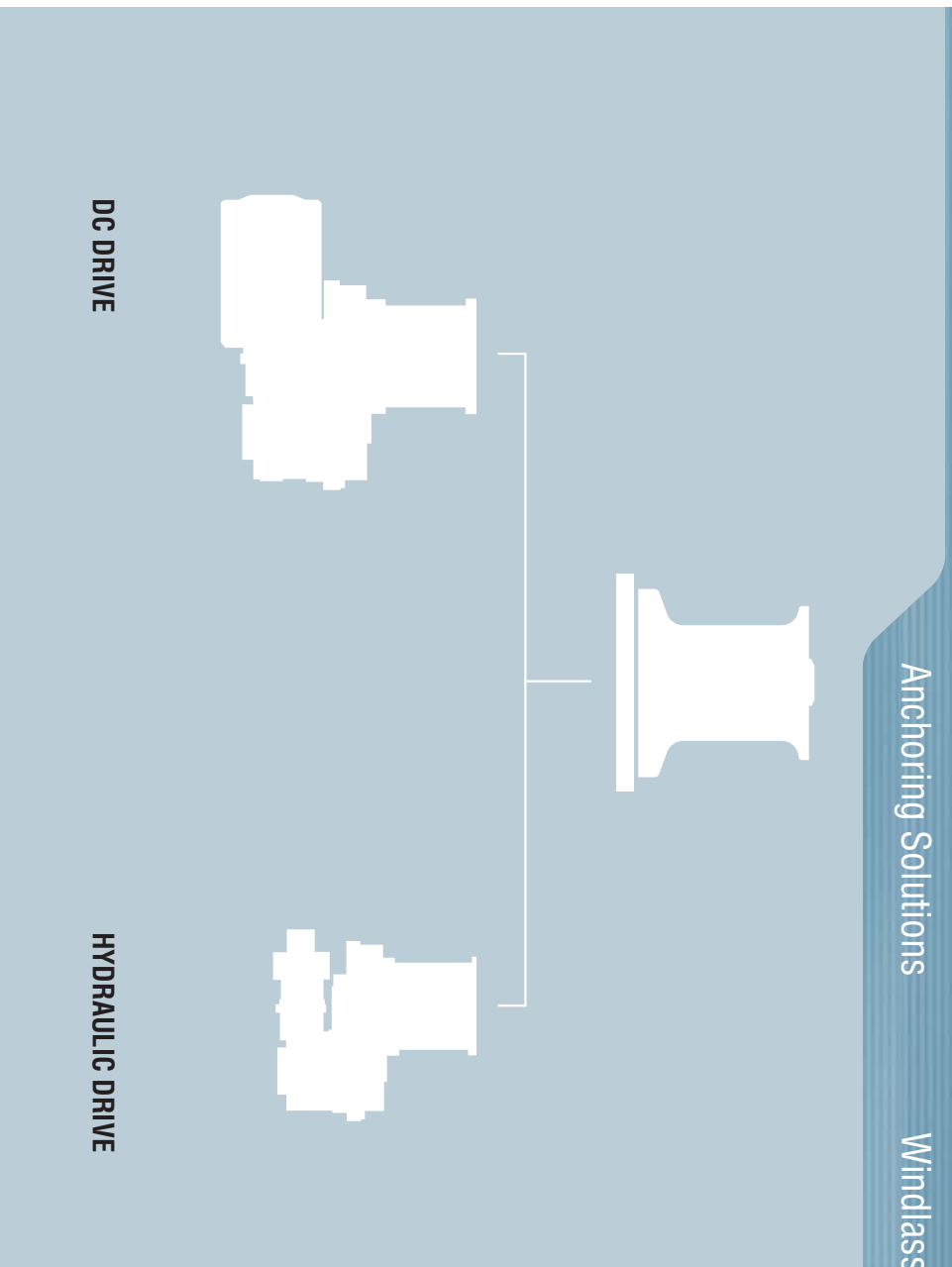

Disclaimer

All information is subject to change without notice. For any critical requirement, use only specifically quoted figures, available on request.

MAXWELL

3500

Introduction • **Topworks** • Drives



Anchoring Solutions

Windlasses

Capstans

Accessories

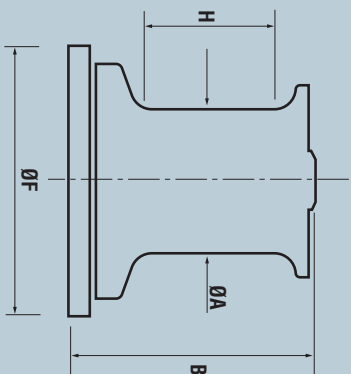

A	145mm 5 3/4"
B	260mm 10 1/4"
F	215mm 8 1/2"
H	160mm 6 5/16"

MAXWELL

3500

Introduction • Topworks • **Drives**

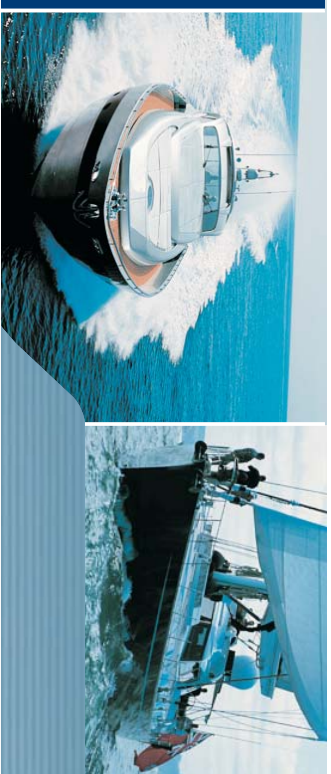

Anchoring Solutions

Windlasses

Capstans

Accessories

DC Drive Specifications

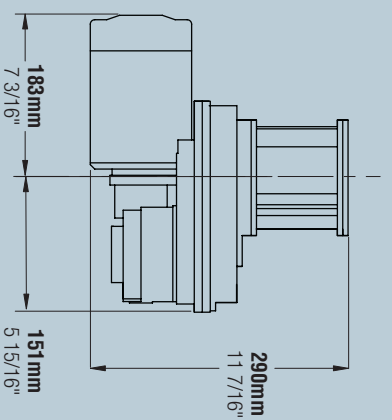

Pull Capacity stall	1591 kg 3500 lb
Motor Power	1.2 kW 1.6 HP
Weight	39 kg 86 lb

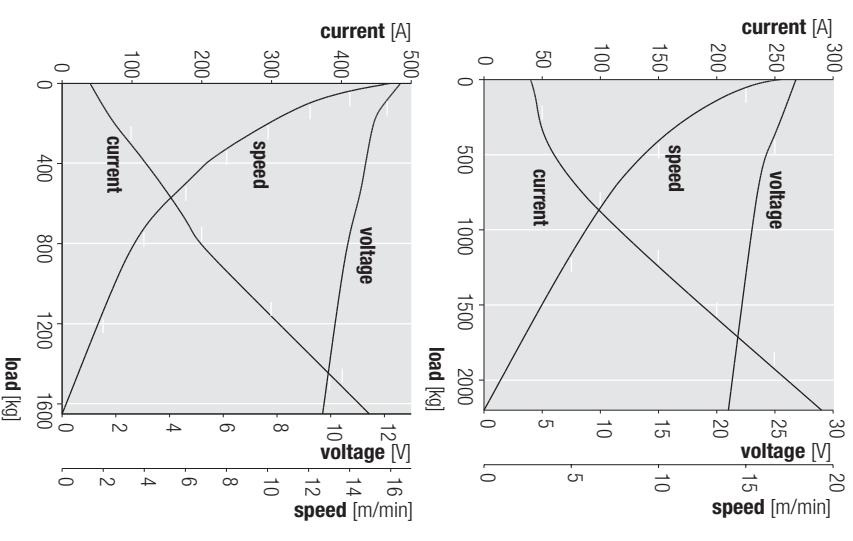

MAXWELL

3500

Introduction • Topworks • **Drives**



Anchoring Solutions

Windlasses

Capstans

Accessories

Hydraulic Drive Specifications

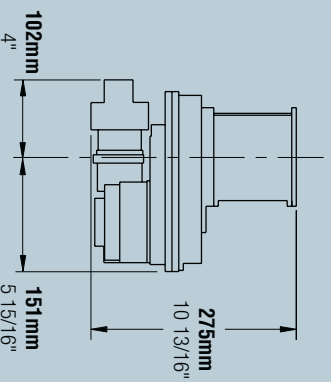

Maximum Pressure - p	138 bar 2000 psi
Pull Capacity	1591 kg 3500 lb
Recommended Flow - Q	42 l/min 11.5 USgal/min
Line Speed @ Q	12 m/min 39 ft/min
Maximum Flow	48 l/min 13 USgal/min
Weight	33 kg 73 lb

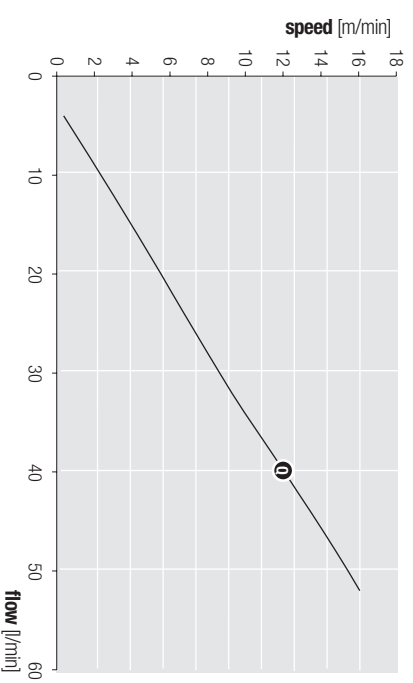
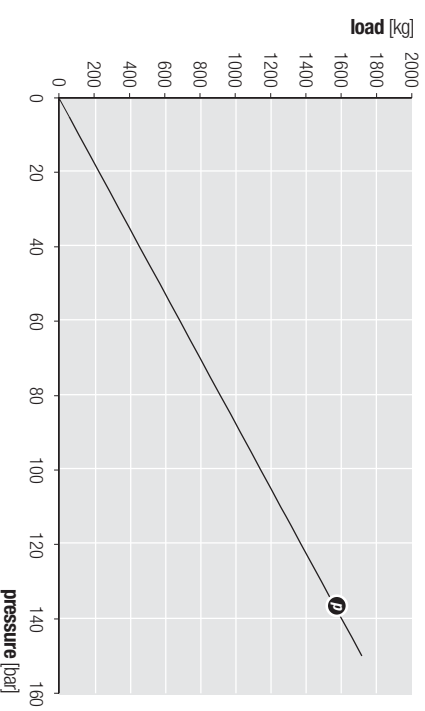

MAXWELL